

Interconnection and Control of Hamiltonian Systems

Carles Batlle

Departament de Matemàtica Aplicada IV

UPC

Overview

- What is a control system?
- The passivity property.
- Control as interconnection.
- Port-controlled Hamiltonian systems (PCHS).
- Dirac structures.
- Casimir functions.
- Interconnection and damping assignment (IDA).
- Summary and outlook.

What is a control system?

$$\dot{x} = f(x, u)$$

$$y = h(x, u)$$

$x \in \mathbb{R}^n$ is the **state** of the system, $u(t) \in \mathbb{R}^m$ is the **control** and $y \in \mathbb{R}^m$ is the **output**, representing what we can measure about the system.

Control objective: choose u so that

- $x(t) \rightarrow x^*$ as $t \rightarrow \infty$ (regulation problem)
- $x(t) \rightarrow x^*(t)$ as $t \rightarrow \infty$ (tracking problem)

- Generally, f contains unknown parameters and disturbances, so a direct solution (**open loop** control) is not feasible in practice.
- Solution: feedback (closed loop) control: choose u as a function of the state x (ideally, as a function of y) so that we use information about what the system is really doing.

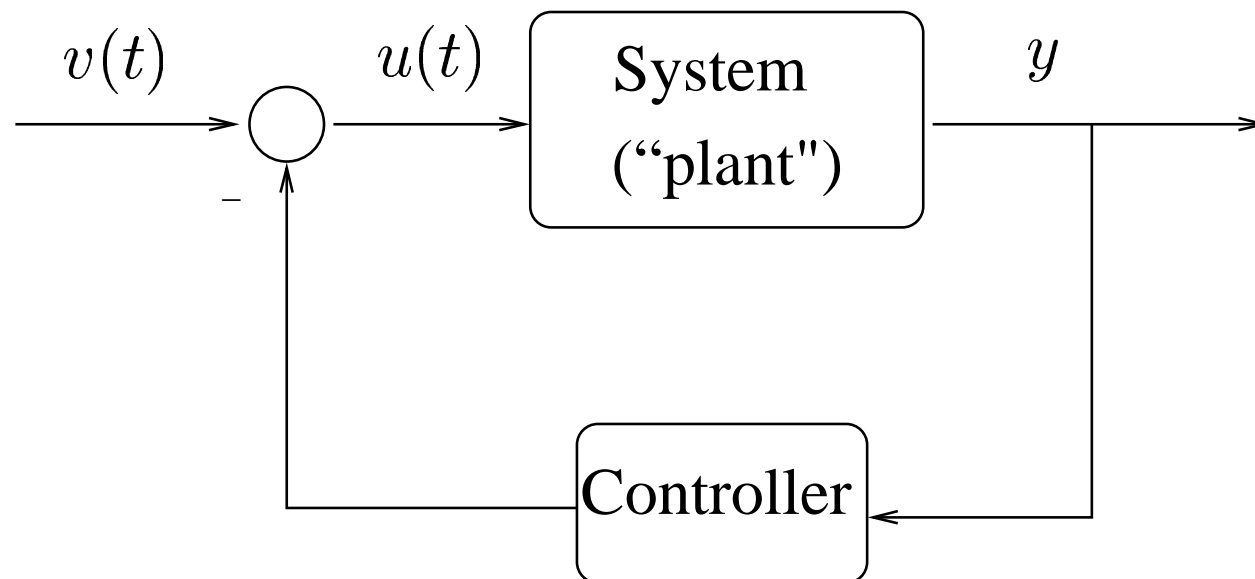

Special case: affine (f, g, h) control systems

$$\dot{x} = f(x) + g(x)u$$

$$y = h(x)$$

Example:

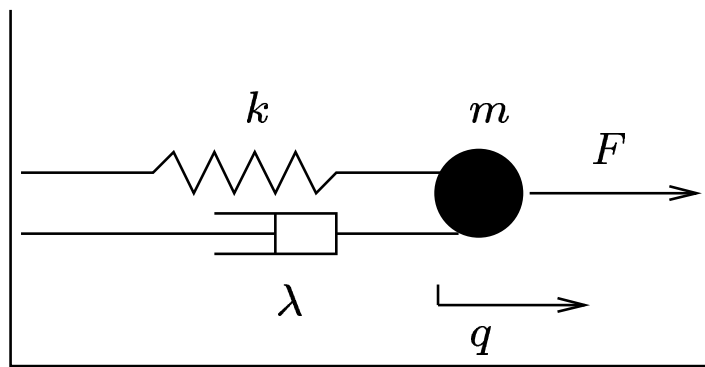

$$x = \begin{pmatrix} q \\ v \end{pmatrix} \text{ state}$$

$$u = F \text{ control}$$

$$y = v \text{ output}$$

$$\frac{d}{dt} \begin{pmatrix} q \\ v \end{pmatrix} = \begin{pmatrix} v \\ -kq - \lambda v \end{pmatrix} + \begin{pmatrix} 0 \\ 1 \end{pmatrix} F$$

- Traditionally, control problems have been approached adopting a signal-processing viewpoint.
- This is very useful for linear time-invariant systems, where signals can be discriminated via filtering.
- For nonlinear systems, frequency mixing invalidates this approach:
 - computations are far from obvious.
 - very complex controls are needed to quench the large set of undesirable signals, and the result is very inefficient, with a lot of energy being consumed and always on the verge of instability (typical example: bipedal walking machines).
- No information about the structure of the system is used.
- Change of control paradigm:

control systems as energy exchanging entities

The passivity property

The map $u \mapsto y$ is **passive** if there exists a state function $H(x)$, bounded from below, and a nonnegative function $d(t) \geq 0$ such that

$$\underbrace{\int_0^t u^T(s)y(s) \, ds}_{\text{energy supplied to the system}} = \underbrace{H(x(t)) - H(x(0))}_{\text{stored energy}} + \underbrace{d(t)}_{\text{dissipated}} .$$

Example: mass-spring-damper system

$$\begin{aligned} \int_0^t F(s)v(s) \, ds &= \int_0^t (m\dot{v}(s) + kq(s) + \lambda v(s))v(s) \, ds \\ &= \left(\frac{1}{2}mv^2(s) + \frac{1}{2}kq^2(s) \right) \Big|_0^t + \lambda \int_0^t v^2(s) \, ds \\ &= H(x(t)) - H(x(0)) + \lambda \int_0^t v^2(s) \, ds. \end{aligned}$$

- Now if x^* is a global minimum of $H(x)$ and $d(t) > 0$, and we set $u = 0$, $H(x(t))$ will decrease in time and the system will reach x^* asymptotically.
- The rate of convergence can be increased if we actually extract energy from the system with

$$u = -K_{\text{di}} y$$

with $K_{\text{di}}^T = K_{\text{di}} > 0$.

- However, the minimum of the natural energy H of the system is not a very interesting point in most engineering problems.

- Key idea of passivity based control (PBC): use feedback

$$u(t) = \beta(x(t)) + v(t)$$

so that the closed-loop system is again a passive system, with energy function H_d , with respect to $v \mapsto y$, and such that H_d has the global minimum at the desired point.

- Passivity for the closed-loop system is far from obvious: physically, the controller is injecting energy into the system.
- PBC is robust with respect to unmodeled dissipation, and has built-in safety: even if we don't know H exactly, if passivity is preserved the system will stop somewhere instead of running away and finally blowing up.

- If

$$-\int_0^t \beta^T(x(s))y(s) \, ds = H_a(x(t)) \quad (1)$$

then the closed-loop system has energy function

$$H_d(x) = H(x) + H_a(x).$$

- One has (**energy-balancing stabilization** property)

$$\underbrace{H_d(x(t))}_{\text{closed-loop energy}} = \underbrace{H(x(t))}_{\text{stored energy}} - \underbrace{\int_0^t \beta^T(x(s))y(s) \, ds}_{\text{supplied energy}}.$$

- For (f, g, h) systems, (1) is equivalent to the PDE

$$-\beta^T(x)h(x) = \left(\frac{\partial H_a}{\partial x}(x) \right)^T (f(x) + g(x)\beta(x)). \quad (2)$$

Example:

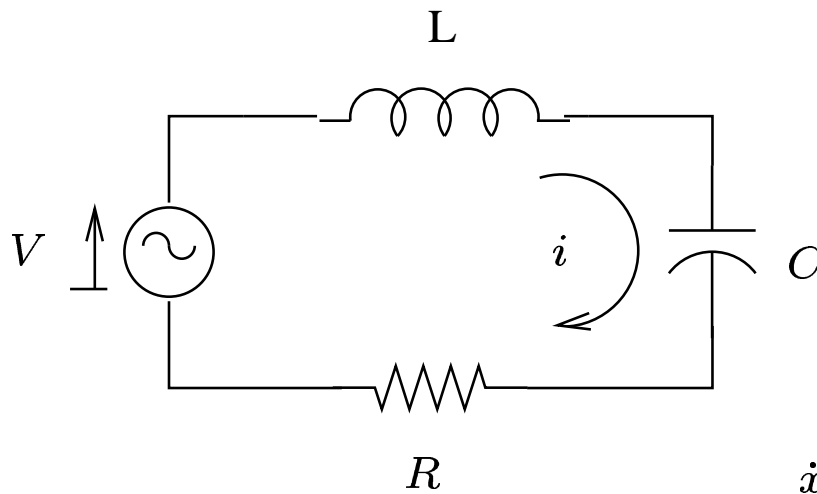

$$x = \begin{pmatrix} q \\ \phi \end{pmatrix} \text{ state}$$

$$u = V \text{ control}$$

$$y = i = \frac{\phi}{L} \text{ output}$$

$$\dot{x} = \begin{pmatrix} x_2/L \\ -x_1/C - x_2R/L \end{pmatrix} + \begin{pmatrix} 0 \\ 1 \end{pmatrix} V(t)$$

The map $V \mapsto i$ is passive with energy function

$$H(x) = \frac{1}{2C}x_1^2 + \frac{1}{2L}x_2^2$$

and dissipation $d(t) = \int_0^t \frac{R}{L^2} \phi^2(s) ds$. Notice that the natural minimum is $(0, 0)$, but forced equilibrium points are of the form $(x_1^*, 0)$.

The PDE (2) is in this case

$$\frac{x_2}{L} \frac{\partial H_a}{\partial x_1} - \left(\frac{x_1}{C} + \frac{R}{L} x_2 - \beta(x) \right) \frac{\partial H_a}{\partial x_2} = -\frac{x_2}{L} \beta(x).$$

Since $x_2^* = 0$ is already a minimum of H , we only have to shape the energy in x_1 . Hence, we can take $H_a = H_a(x_1)$ and the above PDE boils down to

$$\beta(x_1) = -\frac{\partial H_a}{\partial x_1}(x_1)$$

i.e. it defines the closed-loop control. Then we are free to choose H_a so that H_d has the minimum at x_1^* . The simplest solution is

$$H_a(x_1) = \frac{1}{2C_a} x_1^2 - \left(\frac{1}{C} + \frac{1}{C_a} \right) x_1^* x_1 + K$$

where C_a is a design parameter. The closed-loop energy H_d can then be computed and it is seen that it has a minimum at $(x_1^*, 0)$ if $C_a > -C$.

Control as interconnection

- Now we would like to have a physical interpretation of PBC . To be precise, we would like to think of the controller as a **system exchanging energy with the plant**.
- Consider two systems, Σ and Σ_c , exchanging energy through an interconnection network given by Σ_l :

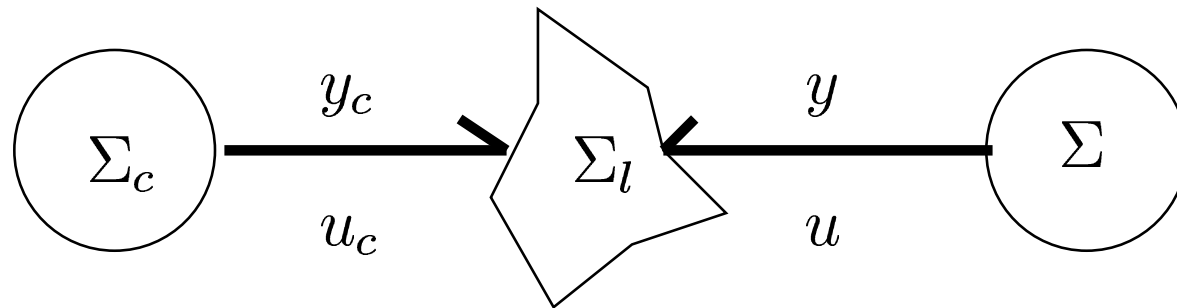

- The interconnection is **power preserving** if

$$u_c^T(t)y_c(t) + u^T(t)y(t) = 0 \quad \forall t.$$

As an example, consider the negative feedback interconnection:

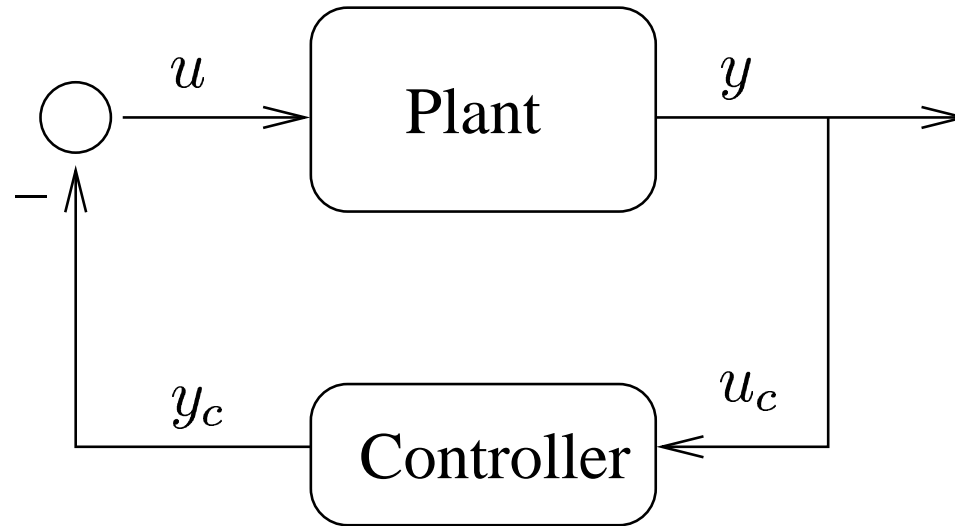

The interconnection is given by

$$u_c = y$$

$$u = -y_c$$

and is clearly power preserving.

- Suppose now that we add some extra inputs $u \rightarrow u + v$, $u_c \rightarrow u_c + v_c$ to the interconnected system. Then it is easy to show the following:

Let Σ and Σ_c have state variables x and ξ . If Σ and Σ_c are passive with energy functions $H(x)$ and $H_c(\xi)$ and Σ_l is power preserving, then the map $(v, v_c) \mapsto (y, y_c)$ is passive for the interconnected system, with energy function

$$H_d(x, \xi) = H(x) + H_c(\xi).$$

Or, in short,

Power preserving interconnection of passive systems yields passive systems.

- Now we have a passive system with energy function $H_d(x, \xi) = H(x) + H_c(\xi)$, but this is not very useful unless we get an energy function depending only on x .
- To solve this, we restrict the dynamics to a submanifold of the (x, ξ) space parameterized by x :

$$\Omega_K = \{(x, \xi) ; \xi = F(x) + K\},$$

and dynamically invariant:

$$\left(\left(\frac{\partial F}{\partial x} \right)^T \dot{x} - \dot{\xi} \right)_{\xi=F(x)+K} = 0.$$

- Instead of solving this in general, we will study a special class of systems.

PCHS

- A **port-controlled Hamiltonian system (PCHS)** with dissipation is given by

$$\dot{x} = (J(x) - R(x)) \frac{\partial H}{\partial x}(x) + g(x)u,$$

$$y = g^T(x) \frac{\partial H}{\partial x}(x),$$

with $J^T(x) = -J(x)$, and $R^T(x) = R(x) \geq 0$.

- A PCHS is passive:

$$\int_0^t u^T y = H(x(t)) - H(x(0)) + \int_0^t \left(\frac{\partial H}{\partial x} \right)^T R(x) \frac{\partial H}{\partial x}.$$

Most energy storing systems can be modelled as PCHS:

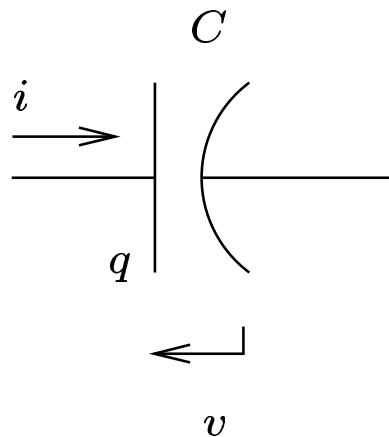

$$\begin{aligned} x &= q \\ u &= i \\ y &= v \end{aligned} \quad H(x) = \frac{1}{2C}q^2$$

$$\begin{aligned} \dot{q} &= (0 - 0) \frac{\partial H}{\partial q} + 1 \cdot i \\ v &= 1^T \cdot \frac{\partial H}{\partial q} = \frac{q}{C}. \end{aligned}$$

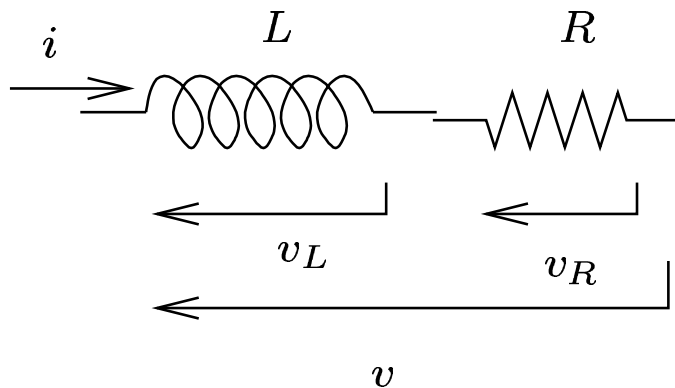

$$\begin{aligned} x &= \phi \\ u &= v \\ y &= i = \frac{\phi}{L} \end{aligned} \quad H(x) = \frac{1}{2L}\phi^2$$

$$\begin{aligned} \dot{\phi} &= (0 - R) \frac{\partial H}{\partial \phi} + 1 \cdot v \\ i &= 1^T \cdot \frac{\partial H}{\partial \phi}. \end{aligned}$$

The essential fact about PCHSs is that, in a given sense, *power preserving interconnection of several PCHS yields a Hamiltonian system (with or without ports).*

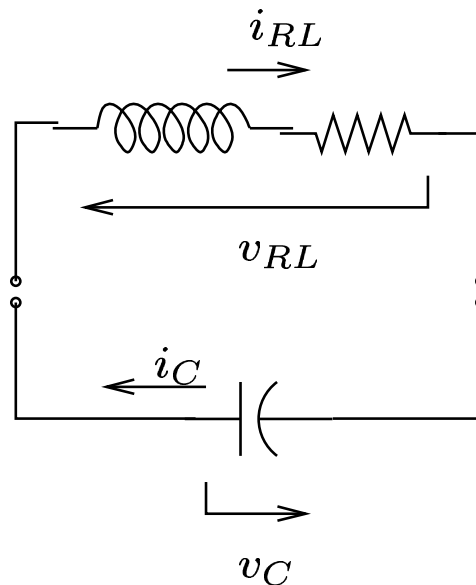

power preserving interconnection
(Kirchoff's laws)

$$v_{RL} + v_C = 0, \quad i_C = i_{RL}$$

$$H(x) = \frac{1}{2C}q^2 + \frac{1}{2L}\phi^2$$

$$\dot{x} = \begin{pmatrix} 0 & 1 \\ -1 & -R \end{pmatrix} \frac{\partial H}{\partial x}$$

The rigorous result (Dalsmo & van der Schaft (1998)) is that interconnection of PCHS by means of what is called a Dirac structure yields an implicit PCHS.

Dirac structures

- Given $\mathcal{D} \subset TM \oplus T^*M$ we define

$$\mathcal{D}^\perp = \left\{ (X, \alpha) \in TM \oplus T^*M ; \langle \alpha | \hat{X} \rangle + \langle \hat{\alpha} | X \rangle = 0, \forall (\hat{X}, \hat{\alpha}) \in \mathcal{D} \right\}.$$

- A **generalized Dirac structure** on an n -dimensional manifold M is a smooth vector subbundle $\mathcal{D} \subset TM \oplus T^*M$ such that

$$\mathcal{D}^\perp = \mathcal{D}.$$

- The fibers of a Dirac structure have dimension n .
- One has a **Dirac structure** if an additional closedness condition (\sim Jacobi identity) is satisfied.
- Taking $\hat{\alpha} = \alpha$, $\hat{X} = X$ one has $\forall (X, \alpha) \in \mathcal{D}$

$$\langle \alpha | X \rangle = 0.$$

This is, with the appropriate identifications, the power preserving condition.

- Let $H \in C^1(M)$. The **implicit generalized Hamiltonian system** on M corresponding to \mathcal{D} and H is given by

$$(\dot{x}, dH) \in \mathcal{D}.$$

- It follows immediately that $\dot{H} = \langle \partial_x H(x) | \dot{x} \rangle = 0$.
- The above system of equations puts, in general, algebraic constraints on M .
- This encompasses the definition of a standard generalized Hamiltonian system

$$\dot{x} = J(x) \frac{\partial H}{\partial x}(x), \quad J(x) = -J^T(x).$$

To show this, define

$$\mathcal{D} = \{(X, \alpha) \in TM \oplus T^*M ; X(x) = J(x)\alpha(x), x \in M\}.$$

Using that in this case every 1-form belongs to a pair in \mathcal{D} , it is easy to show that

$$(X, \alpha) \in \mathcal{D}^\perp \Rightarrow (X, \alpha) \in \mathcal{D}$$

and thus \mathcal{D} is a generalized Dirac structure.

- Under certain constant rank conditions, generalized Dirac structures admit special representations, called I and II. There is a third representation, obtained by dualizing representation II.
- **Representation I.** There exist $n \times n$ matrices $E(x)$, $F(x)$ such that

$$\mathcal{D}(x) = \{(v, v^*) \in T_x M \times T_x^* M ; F(x)v = E(x)v^*\}$$

with $\text{rank}[F(x) : -E(x)] = n$.

- From $\mathcal{D} = \mathcal{D}^\perp$ it follows immediately that

$$E(x)F^T(x) + F(x)E^T(x) = 0.$$

- A generalized Hamiltonian system in this representation is given by

$$F(x)\dot{x} = E(x)\frac{\partial H}{\partial x}(x).$$

- **Representation II.** There exist a distribution G and a skew-symmetric map $J : T^*M \rightarrow TM$ such that

$$\mathcal{D} = \{(X, \alpha) \in TM \oplus T^*M ; X - J\alpha \in G, \alpha \in \text{ann } G\} .$$
- A generalized Hamiltonian system in this representation is given by

$$\begin{aligned} \dot{x} &= J(x) \frac{\partial H}{\partial x}(x) + g(x)\lambda, \\ 0 &= g^T(x) \frac{\partial H}{\partial x}(x), \end{aligned}$$

where g is any full-rank matrix such that $\text{Im } g(x) = G(x)$ and the variables λ enforce the constraints $\phi \equiv g^T \partial_x H$.

- Stability of ϕ fully determines λ , and substitution on the evolution equation yields, on the manifold $\phi = 0$,

$$\dot{x} = J_D(x) \frac{\partial H}{\partial x}(x).$$

- If we define the bracket

$$\{A, B\}_D \equiv (\partial_x A)^T J_D(x) \partial_x B,$$

then

$$\{\phi, H\}_D = 0$$

on $\phi = 0$.

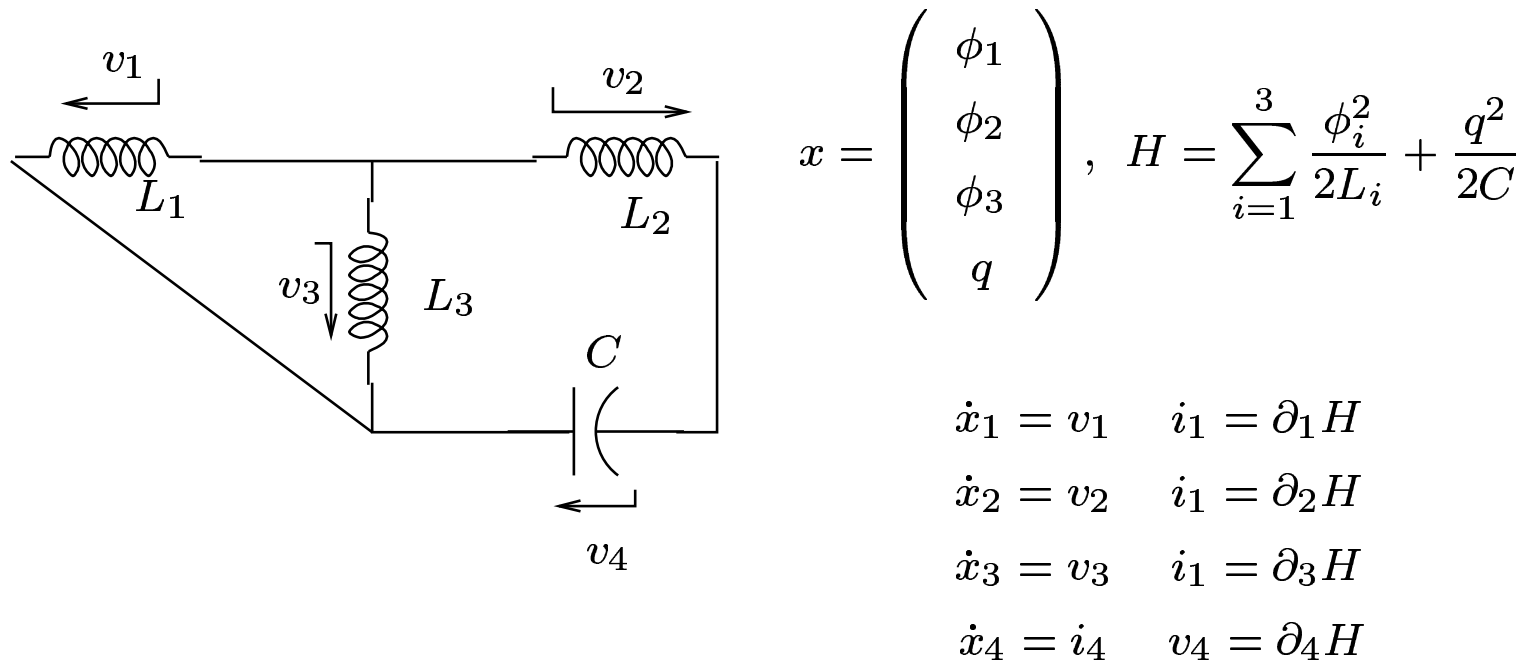

Power preserving interconnection of the 4 individual PCH systems:

$$\begin{aligned} v_1 &= v_3 \\ v_2 + v_4 &= v_3 \\ i_1 + i_2 + i_3 &= 0 \\ i_4 &= i_2 \end{aligned}$$

- Using the interconnection equations, one gets

$$\dot{x}_1 - \dot{x}_3 = 0$$

$$\dot{x}_2 + \partial_4 H = \dot{x}_3$$

$$\partial_1 H + \partial_2 H + \partial_3 H = 0$$

$$\dot{x}_4 = \partial_2 H$$

- Representation I.

$$\begin{pmatrix} 1 & 0 & -1 & 0 \\ 0 & 1 & -1 & 0 \\ 0 & 0 & 0 & 0 \\ 0 & 0 & 0 & 1 \end{pmatrix} \begin{pmatrix} \dot{x}_1 \\ \dot{x}_2 \\ \dot{x}_3 \\ \dot{x}_4 \end{pmatrix} = \begin{pmatrix} 0 & 0 & 0 & 0 \\ 0 & 0 & 0 & -1 \\ -1 & -1 & -1 & 0 \\ 0 & 1 & 0 & 0 \end{pmatrix} \begin{pmatrix} \partial_1 H \\ \partial_2 H \\ \partial_3 H \\ \partial_4 H \end{pmatrix}$$

- Representation II.

$$\begin{pmatrix} \dot{x}_1 \\ \dot{x}_2 \\ \dot{x}_3 \\ \dot{x}_4 \end{pmatrix} = \begin{pmatrix} 0 & 0 & 0 & 0 \\ 0 & 0 & 0 & -1 \\ 0 & 0 & 0 & 0 \\ 0 & 1 & 0 & 0 \end{pmatrix} \begin{pmatrix} \partial_1 H \\ \partial_2 H \\ \partial_3 H \\ \partial_4 H \end{pmatrix} + \begin{pmatrix} 1 \\ 1 \\ 1 \\ 0 \end{pmatrix} \lambda$$

$$0 = \begin{pmatrix} 1 & 1 & 1 & 0 \end{pmatrix} \begin{pmatrix} \partial_1 H \\ \partial_2 H \\ \partial_3 H \\ \partial_4 H \end{pmatrix} \equiv \phi$$

- Stability of ϕ yields, using $\partial_i \partial_j H = 0$ if $i \neq j$,

$$0 = (\partial_1^2 H + \partial_2^2 H + \partial_3^2 H)\lambda - \partial_4 H \partial_2^2 H,$$

from which $\lambda = \frac{\partial_4 H \partial_2^2 H}{\partial_1^2 H + \partial_2^2 H + \partial_3^2 H} \equiv a \partial_4 H.$

- Substitution of λ yields

$$\begin{pmatrix} \dot{x}_1 \\ \dot{x}_2 \\ \dot{x}_3 \\ \dot{x}_4 \end{pmatrix} = \begin{pmatrix} 0 & 0 & 0 & a \\ 0 & 0 & 0 & -1 + a \\ 0 & 0 & 0 & a \\ -a & 1 - a & -a & 0 \end{pmatrix} \begin{pmatrix} \partial_1 H \\ \partial_2 H \\ \partial_3 H \\ \partial_4 H \end{pmatrix}$$

- Consider now N port controlled Hamiltonian systems

$$\begin{aligned}\dot{x}_i &= J_i(x_i)\partial_{x_i}H_i(x_i) + g_i(x_i)u_i \\ y_i &= g_i^T(x_i)\partial_{x_i}H_i(x_i)\end{aligned}$$

with $x_i \in M_i$, Hamiltonians $H_i(x_i)$, controls $u_i \in \mathbb{R}^{m_i} \equiv F_i$ and outputs $y_i \in F_i^*$.

- Link these PCHS by means of a power-conserving interconnection, given by a subspace of dimension $m_1 + m_2 + \dots + m_N$

$$I(x_1, \dots, x_N) \subset F_1 \times F_2 \times \dots \times F_N \times F_1^* \times F_2^* \times \dots \times F_N^*$$

with the property

$$(u_1, \dots, u_N, y_1, \dots, y_N) \in I(x_1, \dots, x_N) \Rightarrow \sum_{i=1}^N y_i^T u_i = 0$$

This yields what is called a **constant Dirac structure** (parameterized by x_i) on the vector space $F_1 \times F_2 \times \dots \times F_N$ (instead of the vector bundle TM).

- The central result is this (Proposition 2.2 in Dalsmo & van der Schaft):

The system resulting from the above interconnection is an implicit generalized Hamiltonian system with state space $M = M_1 \times \cdots \times M_N$, Hamiltonian $H = H_1 + \cdots + H_N$ and Dirac structure \mathcal{D} on M given as follows:

$$(X, \alpha) = (X_1, \dots, X_N, \alpha_1, \dots, \alpha_N) \in \mathcal{D}$$

iff, for all $x_i \in M_i, i = 1, \dots, N$, there exists

$$(u_1, \dots, u_N, y_1, \dots, y_N) \in I(x_1, \dots, x_N)$$

such that

$$\begin{aligned} X_i(x_i) &= J_i(x_i)\alpha_i(x_i) + g_i(x_i)u_i \\ y_i &= g_i^T(x_i)\alpha_i(x_i). \end{aligned}$$

- The result can be extended to the case of a power preserving **partial interconnection**. In this case, the resulting system is port-controlled.

Casimir functions

- More precise results about the possibility of obtaining invariant manifolds expressing the controller variables in terms of the variables of the system can be formulated if both system and controller are PCHS.
- Let thus

$$\Sigma : \begin{cases} \dot{x} &= (J(x) - R(x)) \frac{\partial H}{\partial x}(x) + g(x)u \\ y &= g^T(x) \frac{\partial H}{\partial x}(x) \end{cases}$$

$$\Sigma_c : \begin{cases} \dot{\xi} &= (J_c(\xi) - R_c(\xi)) \frac{\partial H_c}{\partial \xi}(\xi) + g_c(\xi)u_c \\ y_c &= g_c^T(\xi) \frac{\partial H_c}{\partial \xi}(\xi) \end{cases}$$

- With the power preserving, standard negative feedback interconnection $u = -y_c$, $u_c = y$, one gets

$$\begin{pmatrix} \dot{x} \\ \dot{\xi} \end{pmatrix} = \begin{pmatrix} J(x) - R(x) & -g(x)g_c^T(\xi) \\ g_c(\xi)g^T(x) & J_c(\xi) - R_c(\xi) \end{pmatrix} \begin{pmatrix} \frac{\partial H_d}{\partial x} \\ \frac{\partial H_d}{\partial \xi} \end{pmatrix}$$

where $H_d(x, \xi) = H(x) + H_c(\xi)$.

- Let's look next for invariant manifolds of the form $C_K(x, \xi) = F(x) - \xi + K$.
- Condition $\dot{C}_k = 0$ yields

$$\left(\left(\frac{\partial F}{\partial x} \right)^T \mid -\mathbb{I} \right) \begin{pmatrix} J - R & -gg_c^T \\ g_c g^T & J_c - R_c \end{pmatrix} \begin{pmatrix} \frac{\partial H_d}{\partial x} \\ \frac{\partial H_d}{\partial \xi} \end{pmatrix} = 0.$$

- Since we want to keep the freedom to choose H_c , we demand that the above equation is satisfied on C_K for every Hamiltonian, *i.e.* we impose on F the following system of PDEs:

$$\left(\left(\frac{\partial F}{\partial x} \right)^T \mid -\mathbb{I} \right) \begin{pmatrix} J - R & -gg_c^T \\ g_c g^T & J_c - R_c \end{pmatrix} = 0.$$

- Functions $C_K(x, \xi)$ such that F satisfies the above PDE on $C_K = 0$ are called **Casimir functions**. They are invariants associated to the structure of the system (J, R, g, J_c, R_c, g_c) , independently of the Hamiltonian function.

- One can show (Ortega *et al* (2002)) that the PDE for F has solution iff, on $C_K = 0$,
 1. $\left(\frac{\partial F}{\partial x}\right)^T J \frac{\partial F}{\partial x} = J_c$,
 2. $R \frac{\partial F}{\partial x} = 0$,
 3. $R_c = 0$,
 4. $\left(\frac{\partial F}{\partial x}\right)^T J = g_c g^T$.
- Conditions 2 and 3 are easy to understand: essentially, no Casimir functions exist in presence of dissipation. Given the structure of the PDE, $R_c = 0$ is unavoidable, but we can have an effective $R = 0$ just by demanding that the coordinates on which the Casimir depends do not have dissipation, and hence condition 2.

- If the preceding conditions are fulfilled, an easy computation shows that the dynamics on C_K is given by

$$\dot{x} = (J(x) - R(x)) \frac{\partial H_d}{\partial x}$$

with $H_d(x) = H(x) + H_c(F(x) + K)$.

- Notice that, due to condition 2,

$$R(x) \frac{\partial H_c}{\partial x}(F(x) + K) = \underbrace{R(x) \frac{\partial F}{\partial x}}_{=0} \frac{\partial H_c}{\partial \xi}(F(x) + K) = 0,$$

so we can say that

dissipation is only admissible for those coordinates which do not require energy shaping.

IDA

- Shortcomings of the PBC of interconnected PCHS:
 - Nonlinear PDE for the Casimir function.
 - Dissipation obstacle.
- One can get a method with more freedom if not only the energy function is changed but also the interconnection (J) and the dissipation (R), *i.e.* one aims at a closed-loop system of the form

$$\dot{x} = (J_d(x) - R_d(x)) \frac{\partial H_d}{\partial x}(x),$$

where $J_d^T(x) = -J_d(x)$, $R_d^T(x) = R_d(x) > 0$, and x^* a minimum of $H_d(x)$.

One has the following fundamental result (Ortega *et al* (2002)):
 If one can find a (vector) function $K(x)$, a function $\beta(x)$, an antisymmetric matrix $J_a(x)$, and a symmetric, semipositive definite matrix $R_a(x)$ such that

$$\begin{aligned} (J(x) + J_a(x) - R(x) - R_a(x))K(x) = & \quad (3) \\ - (J_a(x) - R_a(x)) \frac{\partial H}{\partial x}(x) + g(x)\beta(x), & \end{aligned}$$

with K the gradient of a scalar function, $K(x) = \frac{\partial H_a}{\partial x}(x)$, then the closed loop dynamics with $u = \beta(x)$ is a Hamiltonian system with $H_d = H + H_a$, $J_d = J + J_a$, $R_d = R + R_a$. One can then try to impose conditions on H_a (or on K) so that x^* is an asymptotically stable point of the dynamics. This is called IDA-PBC.

- To solve the PDE (4) one can fix $J_a(x)$ and $R_a(x)$.
Pre-multiplying by a left annihilator of $g(x)$ yields a linear PDE for H_a . After solving it, $\beta(x)$ can be computed using $(g^T(x)g(x))^{-1}$.
- It can be shown that
 - IDA-PBC generates all asymptotically stabilizing controllers for PCH systems.
 - If $R\partial_x H_a = 0$, IDA-PBC is energy-balancing.
 - If, additionally, $J_a = R_a = 0$, one can think of IDA-PBC in terms of a Casimir function $C(x, \xi) = -H_a(x) - \xi$, a feedback interconnection modulated by $\beta(x)$ and a controller with energy $H_c(\xi) = -\xi$.

Magnetic levitation system

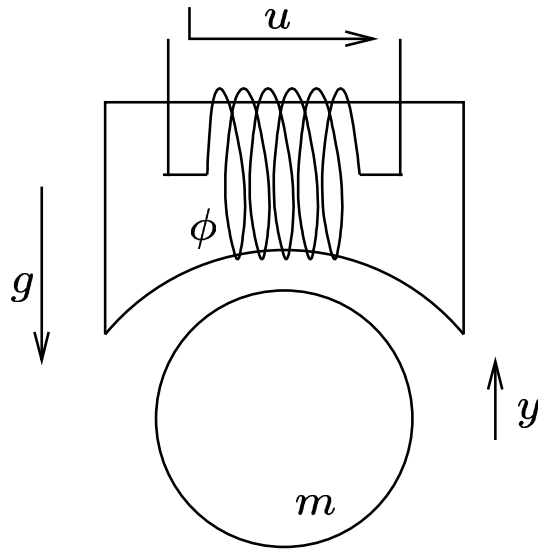

$$\begin{aligned}\dot{\phi} &= -Ri + u \\ \dot{y} &= v \\ m\dot{v} &= \frac{\partial L}{\partial y}(y) i^2 - mg\end{aligned}$$

$$\phi = i L(y), \quad L(y) = \frac{k}{a - y}$$

Taking $x_1 = \phi$, $x_2 = y$, $x_3 = mv$, this can be written as a PCH

$$\dot{x} = \left[\begin{pmatrix} 0 & 0 & 0 \\ 0 & 0 & 1 \\ 0 & -1 & 0 \end{pmatrix} - \begin{pmatrix} R & 0 & 0 \\ 0 & 0 & 0 \\ 0 & 0 & 0 \end{pmatrix} \right] \frac{\partial H}{\partial x} + \begin{pmatrix} 1 \\ 0 \\ 0 \end{pmatrix} u$$

with Hamiltonian

$$H(x) = \frac{1}{2k}(a - x_2)x_1^2 + \frac{1}{2m}x_3^2 + mgx_2.$$

- Given a desired y^* , the equilibrium point is

$$x^* = \begin{pmatrix} \sqrt{2kmg} \\ y^* \\ 0 \end{pmatrix}.$$

- The key IDA-PBC equation $(J - R)K(x) = g\beta(x)$ yields in this case

$$\begin{aligned} -RK_1(x) &= \beta(x) \\ K_3(x) &= 0 \\ -K_2(x) &= 0, \end{aligned}$$

and we see that $H_a(x) = H_a(x_1)$, which can be choosed so that

$$H_d(x) = H(x) + H_a(x_1)$$

has a critical point at $x = x^*$.

- Unfortunately

$$\frac{\partial^2 H_d}{\partial x^2}(x) = \begin{pmatrix} \frac{1}{k}(a - x_2) + H_a''(x_1) & -\frac{x_1}{k} & 0 \\ -\frac{x_1}{k} & 0 & 0 \\ 0 & 0 & \frac{1}{m} \end{pmatrix}$$

has at least one negative eigenvalue no matter what H_a we choose, so x^* will not be asymptotically stable.

- The source of the problem is the lack of coupling between the mechanical and magnetic part in the interconnection matrix J .
- To solve this, we aim at

$$J_d = \begin{pmatrix} 0 & 0 & -\alpha \\ 0 & 0 & 1 \\ \alpha & -1 & 0 \end{pmatrix}, \quad i.e. \quad J_a = \begin{pmatrix} 0 & 0 & -\alpha \\ 0 & 0 & 0 \\ \alpha & 0 & 0 \end{pmatrix}.$$

- Taking $R_a = 0$, the IDA-PBC equation now becomes

$$\begin{aligned} -RK_1(x) &= \frac{\alpha}{m}x_3 + \beta(x) \\ K_3(x) &= 0 \\ \alpha K_1(x) - K_2(x) &= -\frac{\alpha}{k}(a - x_2)x_1, \end{aligned}$$

- Now $H_a = H_a(x_1, x_2)$. The first equation yields the control $u = \beta(x)$ and the last equation has solution

$$H_a(x_1, x_2) = \frac{1}{6k\alpha}x_1^3 + \frac{1}{2k}x_1^2(x_2 - a) + \Phi(x_2 + x_1/\alpha).$$

- Finally we get

$$H_d(x) = \frac{1}{6k\alpha}x_1^3 + \frac{1}{2m}x_2^2 + mgx_2 + \Phi(x_2 + x_1/\alpha)$$

and it can be checked that Φ can be choosed so that H_d has a minimum at the desired point.

Summary and outlook

- Passivity based control
 - provides a physical understanding of control.
 - uses energy as a fundamental concept, providing a *lingua franca* between different domains.
 - offers a new approach to the control of nonlinear systems and (hopefully) improved performance.
- PCHS theory gives a modular description of systems and
 - allows to treat systems at different levels of detail.
 - has a natural link with bond graph theory and hence with advanced simulation techniques.
 - opens the possibility of designing libraries of reusable models and controls.

Present and future research

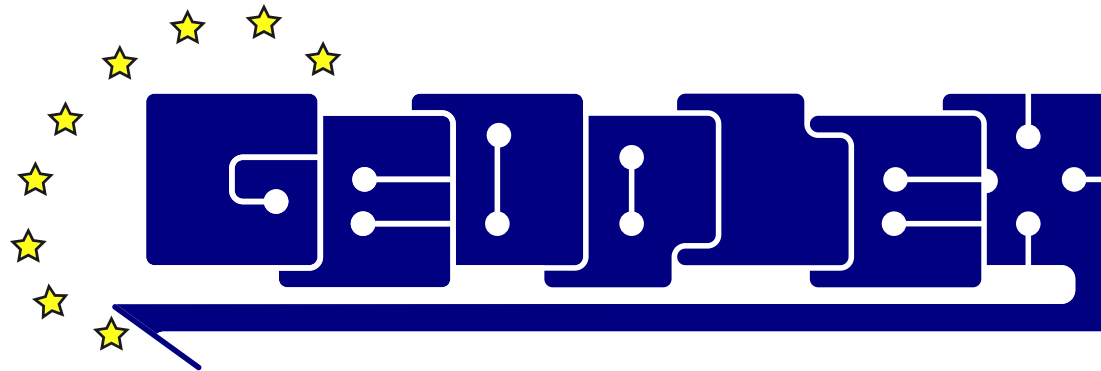

www.geoplex.cc

- Mathematical study of the PDEs involved.
- Modeling and control of several electrical energy conversion systems using PCHS and PBC.
- Trajectory tracking.
- Non-smooth systems: Casimir functions and relation with averaged models.

References

General texts in control theory

- J.-J. E. Slotine and Weiping Li, **Applied nonlinear control**, Prentice Hall (1991).
- H. K. Khalil, **Nonlinear Systems**, MacMillan (1996).
- A. van der Schaft, **L_2 gain and passivity techniques in nonlinear control**, Springer (1999).

Dirac structures, interconnection and PCHS

- P.C. Breedveld *et al*, An intrinsic Hamiltonian formulation of the dynamics of *LC*-circuits, *IEEE Trans. on Circuits and Systems — I* **42**, pp. 73-82 (1995).
- M. Dalsmo and A. van der Schaft, On representations and integrability of mathematical structures in energy-conserving physical systems, *SIAM J. Control Optim.* **37**, pp. 54-91 (1998).
- R.Ortega *et al*, Interconnection and damping assignment passivity-based control of port-controlled Hamiltonian systems, *Automatica* **38**, pp. 585-596 (2002).